

ABB monitoring and communications VSN800 Weather Station



The VSN800 Weather Station automatically monitors site meteorological conditions and photovoltaic panel temperature in real-time, transmitting sensor measurements to the Aurora Vision® Plant Management Platform.

The VSN800 contains the essential environmental sensor set needed for solar monitoring.

The expanded sensor set enables plant management across a broad range of plant sizes.

VSN800 is a companion to the VSN700 Data Logger, the VSN730 System Monitor, or the VSN750 Plant Manager where it is fully compatible and integrates seamlessly with the Aurora Vision® Plant Management Platform.

Shipped preconfigured and ready for installation, requiring no special tools.

The VSN800 Weather Station is delivered ready for installation and requires the installer to mechanically mount the modules on a user-supplied mast, connect power and

communication, and initialize the automatic system commissioning process from the VSN700. No special software, or on-site calibration is required.

The all-in-one weather station reduces the installation, support and maintenance cost as well as improves the robustness and manageability of the PV plant monitoring solution.

The basic sensor set provides data needed to calculate a performance ratio allowing a plant operator to track solar array performance against expected energy production

The advanced sensor set improves monitoring of weather conditions that can effect energy production. The extra irradiance sensor for mounting at the plane of the array allows more accurate measurement of irradiance that is incident in the plane of the solar panels. Wind speed and direction sensor gives the operator information about how the wind may be cooling the panels and some indication of how much dust may be accumulating on the panels.

Highlights

- Two models offered for basic and advanced sensor sets
- VSN800-12 includes a basic sensor set: ambient temperature, solar irradiance, and back of module temperature
- VSN800-14 includes an additional advanced sensors: plane of array irradiance and wind direction and speed
- Sensors, data acquisition unit, and RS-485 communication all in a single unit

Block diagram of VSN800 Weather Station

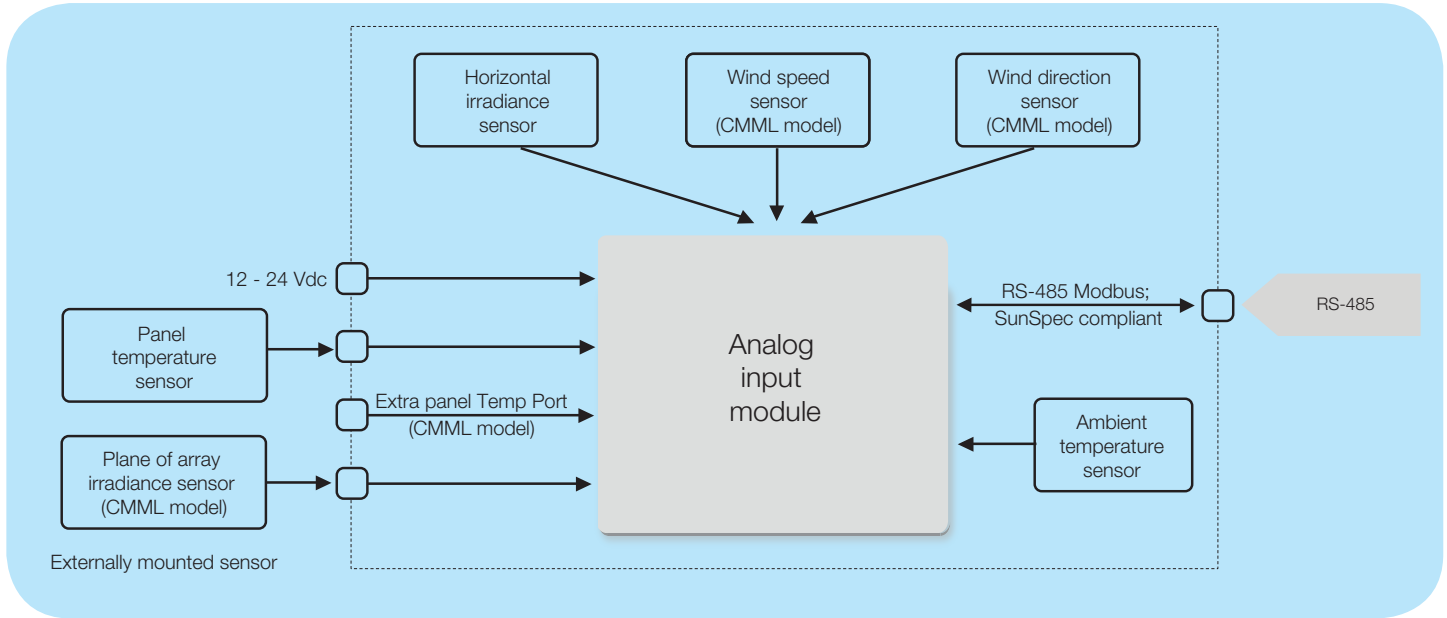

BCD.00392 ABB-VSN800 EN REV E 03.01.2016

Technical data and types

| Type code | VSN800-12 | VSN800-14 |
|-----------------------------|--|---|
| Sensors | | |
| Ambient temperature | Range -40°F to 176°F (-40°C to 80°C) Accuracy +/- 0.54°F (0.3°C) | |
| PV panel temperature | Range -40°F to 176°F (-40°C to 80°C) Accuracy +/- 0.54°F (0.3°C) Cable length 25ft (7.62m) | |
| Solar radiation | Range 0 to 1750W/m2 Accuracy +/- 5% Temperature range -13°F to 131°F (-25°C to 55°C) | |
| Number of radiation sensors | 1 horizontal | 1 horizontal, 1 plane of array |
| Wind direction | N/A | Range 360 degrees Accuracy +/- 22.5° Threshold 2 MPH (0.89m/s) Temp range -40°F to 140°F (-40°C to 60°C) |
| Wind speed | N/A | Range 0 to 150 MPH (0 to 67m/s) Accuracy is Greater of 1 mph (0.45m/s) or 5% Threshold 2 MPH (0.89m/s) Temp range -40°F to 140°F (-40°C to 60°C) |
| Communication | | |
| Serial port | RS-485 2 wire, Modbus RTU, SunSpec Alliance compliant, 8/N/1, max speed 19200 | |
| Terminal block | #22 - #18 AWG | |
| Recommended cable | Belden #1120A or equivalent | |
| Power supply | | |
| DC power supply input | 10-30 VDC, 50mA | |
| Terminal block | Accepts AWG #22 - #18 | |
| Compliance | | |
| EMC | FCC Part 15, Subpart B; ICES-003; EN 61326-1:2006; Emission class B, Immunity is class A | |
| Enclosure | UL 94 V-2, ROHS compliant, IP65 | |
| Humidity | 0 to 100% condensing | |
| Physical parameters | | |
| Dimensions HxWxD | 20.9" x 5.1" x 4.7" (0.53m x 0.13m x 0.12m) | 24.8" x 9.8" x 13" (0.63m x 0.25m x 0.33m) |
| Weight | 1.75lb (0.8kg) | 7lb (3.2kg) |
| Ambient temperature range | -13°F to 131°F (-25°C to 55°C) | |
| Mounting | Pole or tripod | |
| Warranty | | |
| Standard warranty | Two years | |

Support and service

ABB supports its customers with a dedicated, global service organization in more than 60 countries, with strong regional and national technical partner networks providing a complete range of life cycle services.

For more information please contact your local ABB representative or visit:

www.abb.com/solarinverters

www.abb.com

© Copyright 2015 ABB. All rights reserved. Specifications subject to change without notice.

